

The two-roll plasticiser (TRP)

A new process technology closes a gap in the processing of rework materials in the tyre industry

The TRP Reworker is a resource-saving technology for the economical processing of rework materials based on the two-roll plasticiser (TRP) with integrated roll-ex gear pump. In an automatic process, unvulcanised rubber compounds are processed particularly gently and continuously in order to return this rework material to the production process. In tyre production compound waste is unavoidable due to the process. This material should be reworked with regard to the issues of sustainability and the economical handling of valuable resources, and not least because of the high raw material costs. Based on the Uth TRP technology, the company has developed the TRP Reworker. This new process technology combines the proven methods in rubber processing such as cracking, homogenising and discharging, thus closing a gap in the processing of rework materials. The concept is based on TRP technology and comprises three zones along the length of the roll, resulting in a continuous, reproducible and fully automated process.

Introduction

The tyre is a complex high-tech product consisting of over ten different rubber compounds and over twenty components. For this reason, tyre production is a very complex and high-precision process. During the individual process steps a considerable amount of base material residues falls to waste. This so-called rework material consists of high-quality raw materials. In terms of sustainability and the economical handling of valuable resources and not least because of the high raw material costs, it should not be disposed of. Tyre manufacturers are pursuing the worthwhile aim of processing this material as gently as possible into a high-

quality intermediate product so that it can be returned to the production process. A material-friendly preparation process is crucial – the better the quality, the higher the return rate. With smaller and smaller batch

sizes for a larger number of specialised tyres, the absolute amount of rework material is increasing worldwide. This creates a need to collect this material in order to be able to return it to the production line by means of a reproducible and economical rework process.

State-of-the-art

During the rework process the material is first plasticised, homogenised and then discharged so that it can be blended with fresh material. Today the reprocessing steps often take place cyclically in the same production lines in which the preliminary products are also manufactured, e.g., internal mixer or open mill lines (fig. 1 and fig. 2).

The use of open mills has been proven to ensure good temperature control and is therefore particularly well-suited for a material-friendly reprocessing process. Due to the cyclical accumulation of rework material, the entire process has to be carried

Fig. 1: Internal mixer line

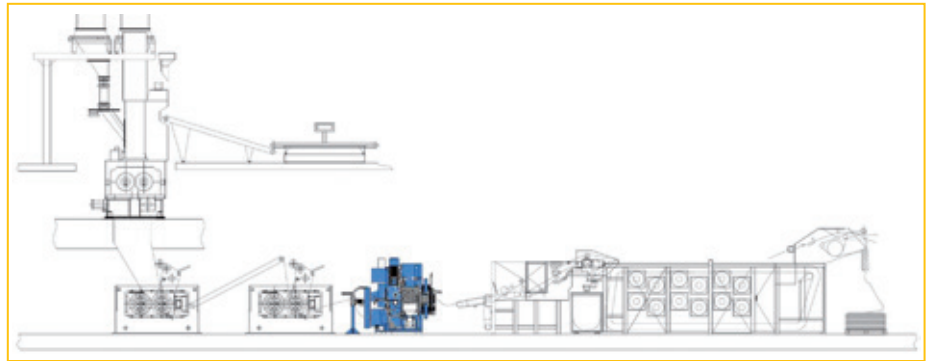
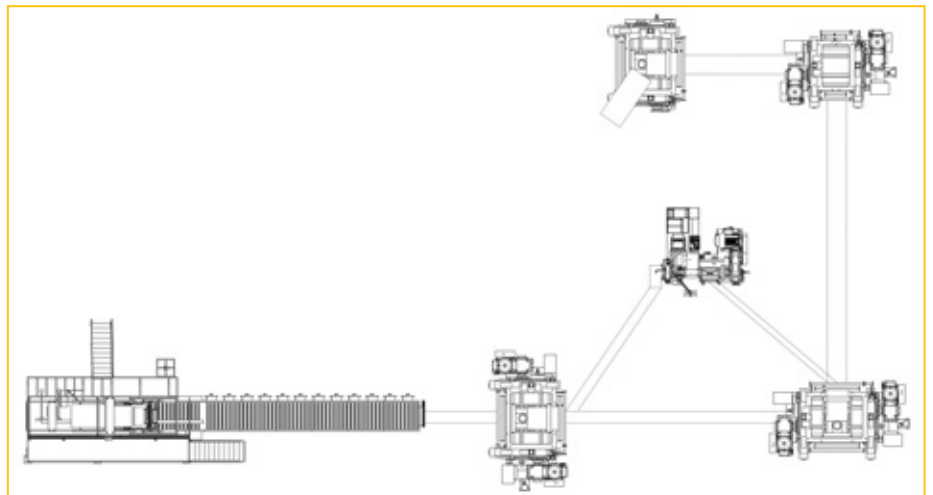

Fig. 2: Open-mill line



Peter J. Uth
Managing Director

Julia Uth
Assistant to the management

Manuel Beßler
mbessler@uth-gmbh.com
General Manager Sales and Project Management

Uth GmbH, Fulda, Germany
www.uth-gmbh.com

All figures and tables, unless otherwise stated, have been kindly provided by the authors.

out manually, which increases the risk potential for the operator. In addition, reproducible quality is difficult to ensure, as it depends on the operator's experience and

skills in controlling the open mill process. The reprocessing of rubber compound in the internal mixer line is better to control than the open mill lines and causes less risk

for the operator. However, on the process technology side, the rework material experiences relatively high shear forces and thus increased temperatures which can further harm the material that is already under stress. To ensure a gentle process, the internal mixer must be set at quite a slow rotor speed which results in comparatively long mixing times. The cost efficiency of the cyclic reprocessing process is also lessened by high energy and space requirements as well as the cost of machine minutes for the entire mixing line.

Basic principles of TRP technology

The two-roll plasticiser (TRP) with integrated gear pump from Uth has been established as a solution which meets these requirements. The automatic and continuous process combines proven technologies in rubber processing such as cracking, homogenising and discharging. The basic principle is based on an open-roll system combined with the roll-ex gear pump technology.

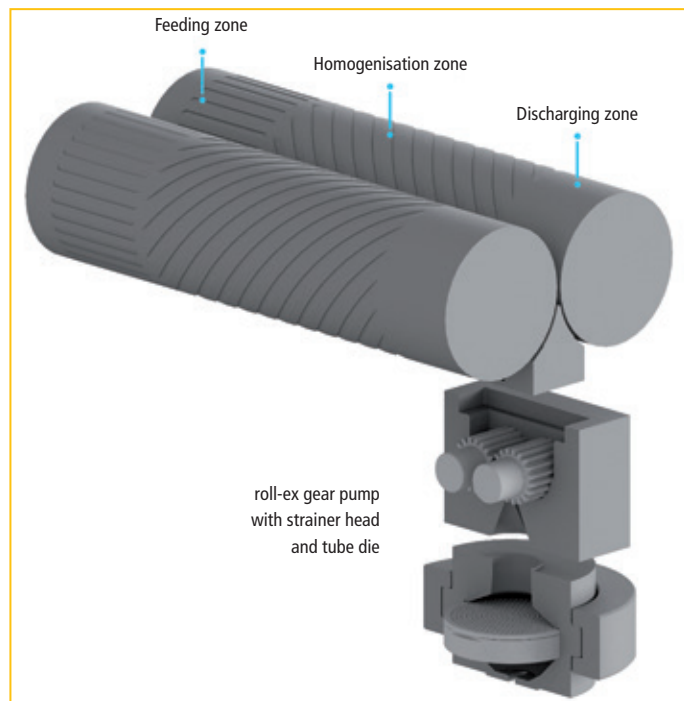

Fig. 3:
The basic principle of TRP technology

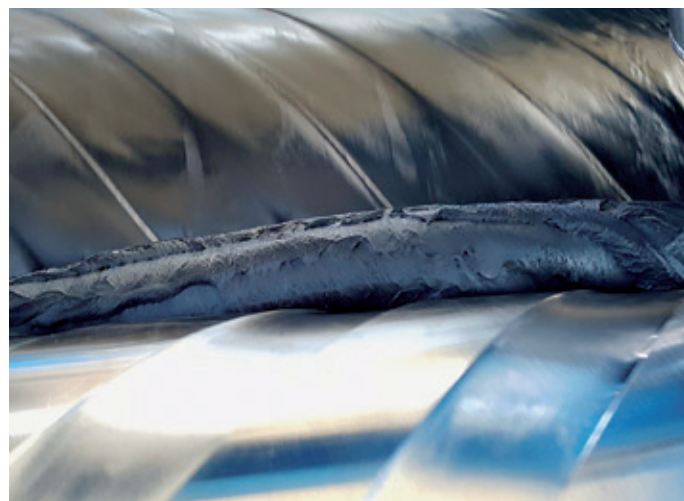

Fig. 4:
Homogenisation of the compound on the nip of the open-mill

The compact system consists of three zones located along the length of the roll (**fig. 3**). In the feeding zone materials of various types and shapes, such as slabs, sheets or shaped profiles, can be fed by a conveyor. During the process a mechanically effected transformation takes place in the nip of the homogenisation zone in which the material is plasticised and homogenised (**fig. 4**). According to the roll-ex TRF principle, the material is then directly extruded in the discharging zone. The manual intervention of an operator in the process area is therefore no longer required and is also prevented by a full housing of the processing area. The final outcome is a safe, controlled and continuous homogenisation process with reproducible results. Due to the modular concept, the TRP offers the option of an integrated gear pump extruder for the gentle fine-mesh straining of the material.

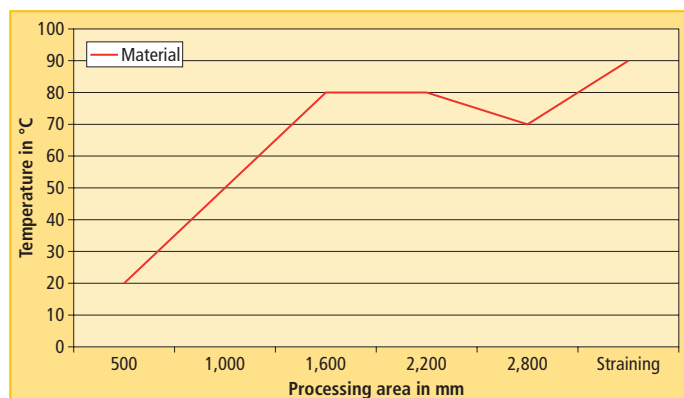

Fig. 5:
Temperature profile along the rolls

The basis for a gentle rework process is a controlled temperature development (**fig. 5**). In TRP process technology, this is guaranteed by temperature zones that can be set differently across the entire length of the rolls. Good homogenisation and plastifi-

cation performance is achieved by mechanical transformation of the compound. The required friction, which increases the plasticising performance, can be optimised for the respective process by means of different roller speeds and gap adjustments. A roll design, which is especially designed for the rework process, also enables an axial material transport from the feeding zone to the discharging zone.

Design of the TRP Reworker system

Based on the two-roll plasticiser, a system solution has been developed to meet the demands of the rework process in the tyre industry (fig. 6). In addition to the core component, the plasticising unit, the modular concept consists of several system components and thus enables application-specific solutions.

The feeding unit

Rework materials such as treads, sidewalls or profiles usually are varying in geometry and piece weight. A continuous homogenisation process is, however, necessary for a controlled process and reproducible results. The discontinuous feeding is coupled with a continuous process by the feeding unit. The material is first transported to a weighing and cutting device via a horizontal belt conveyor before it passes through the metal detector and is then fed to the plasticising unit via an ascending conveyor. Alternatively,

slabs can be fed directly from a pallet using a slab feeder and cutting device.

The plasticising unit

The plasticising unit of the TRP Reworker is based on the process technology of the two-roll plasticiser. A feeding zone, especially tailored to the rework process, enables the processing of materials with different rheological properties. Common rework materials in the tyre industry are, for example, truck or car tread compounds with a hardness of 60–70 Shore A and a Mooney viscosity of 50–60 units, sidewall compound with a hardness of 40–55 Shore A and a Mooney viscosity of 50–60 units or apex material

with a hardness of 60 Shore A and a Mooney viscosity of 75 units. All the rework materials deriving from these components can be easily reworked in the plasticising unit. The same also applies to ply- or inner liner compound.

The TRP discharging zone

The discharging zone of the plasticising unit is based on the proven roll-ex TRF principle (two-roll feeding unit). The following gear extruder is actively fed by two temperature-controlled rolls. When the material leaves the roll-nip, the feed pressure is generated which is necessary to completely fill the teeth of the gear pump. In the material discharge zone, the temperature of the ma-

Fig. 6: The complete solution – TRP Reworker

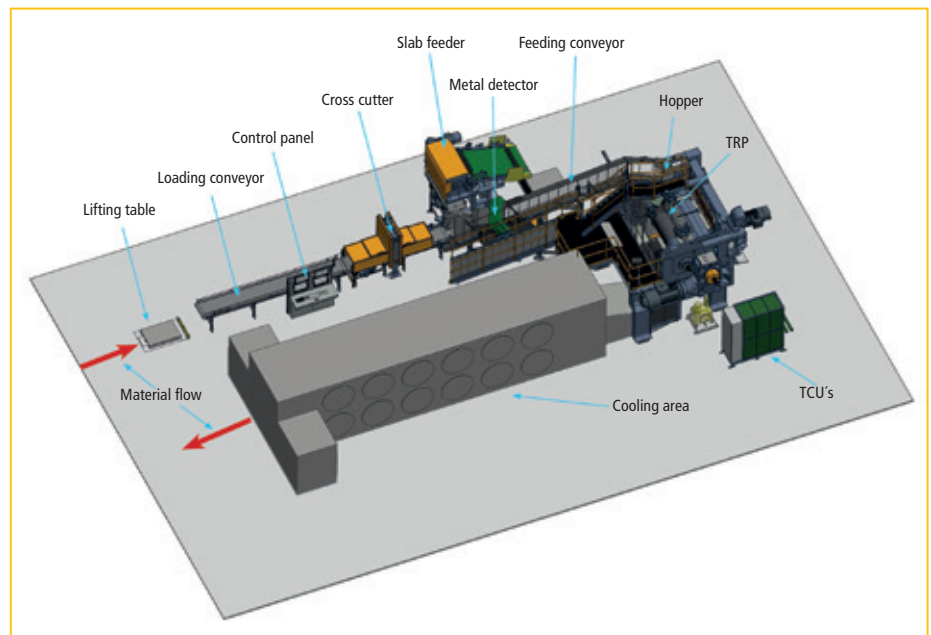
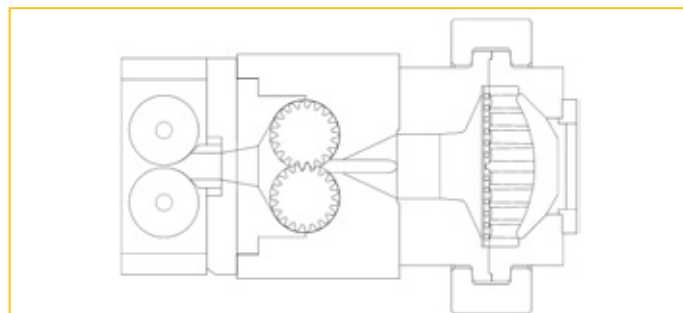

Fig. 7: Gear pump extruder with two-roll feeder



The meaning of fine-mesh straining

Fine-mesh straining is the fine filtration of rubber or silicone compounds. Impurities are retained in a screen and removed from the material flow. Depending on the compound quality and mesh size, pressures of several hundred bar are required for this process.

Fig. 8: TRP Reworker 2800 with integrated gear pump



terial can be modified by means of a separate temperature-controlled zone (**fig. 5**) which provides additional temperature variations for subsequent processes.

The strainer gear pump unit

In the standard configuration a roll-ex gear pump-strainer unit is positioned under the TRP discharging zone. The gear pump and the strainer head can be hydraulically swivelled away from the TRP for cleaning and screen changing purposes. Temperature sensors record the temperature in the discharging zone of the plasticising unit (in front of the gear pump) and in the strainer head to allow monitoring of the temperature development.

Process requirements

- Feeding of rubber compound or rework material with different specifications and shapes
- Sufficient plasticisation and homogenisation with gentle material treatment
- Good access to the processing area for cleaning and material change
- Reproducible and automated processing with minimum of operator workload

The gear extruders work on the principle of positive displacement pumps. At the entering side of the pump the material is retracted, transported in the space width of two inter-combing gears and then displaced from these spaces by the inter-locking of the gears. This displacement results in the building of pressure and further material transport (**fig. 7**).

The cooling section

The rubber compound can be cooled in conventional cooling systems. Depending on the form of the discharged compound, cantilever cooling sections or classic batch-off systems are suitable for palletising sheets. Since the temperatures of the batches are approxi-

mately 100 °C and due to the relatively slow speeds, e.g., between 5–9 m/min in the case of a sheet extrusion, the cooling sections can be of relatively compact dimensions.

The state of development and future outlook

The TRP technology has established itself in the tyre industry as an alternative solution for the processing of rework materials. The TRP Reworker of the size of the 2800 model has a throughput of 2,500 kg/h and thus meets the usual rework requirements in a tyre factory (**fig. 8**). Other sizes and designs can provide options for other processing tasks in rubber and silicone processing, such as preheating, mixing and discharging.

Advantages of the TRP Reworker

- During rework process the material is processed particularly gently and continuously with very good temperature control.
- Automated processes for reproducible results.
- The system has a modular design: an integrated roll-ex gear pump with the option of fine-mesh straining allows discharge of the material in different shapes.
- The process area is completely enclosed and thus ensures a high level of work safety.
- Due to the compact, space-saving design, space costs can be reduced.
- Good access to the system components for cleaning and compound changes.
- Up to 50 % energy savings compared to existing processes.
- At least 5 % of raw materials in tire production can be saved by using the TRP technology.
- 98 % of the process-related waste can be returned to the tire manufacturing process.